

THE DUOLINE SERIES

12-00198

rev_2

Television and DSTV Protection

Features

- Plug-and-Play concept
- High surge capability
- Fire hazard protection
- Protection indication lamps

Clearline protects your Television, Mnet, PVR, decoder, Satellite decoder and VCR against lightning and surges without additional earthing.

The protection modules have multiple stages of protection capable of blocking severe lightning and power surges.

Clearline incorporates a fast overload device which will be activated in extreme conditions. Functional indication lamps display the protection status of the unit.

Clearline's unique built-in thermal protection devices eliminates fire hazards.

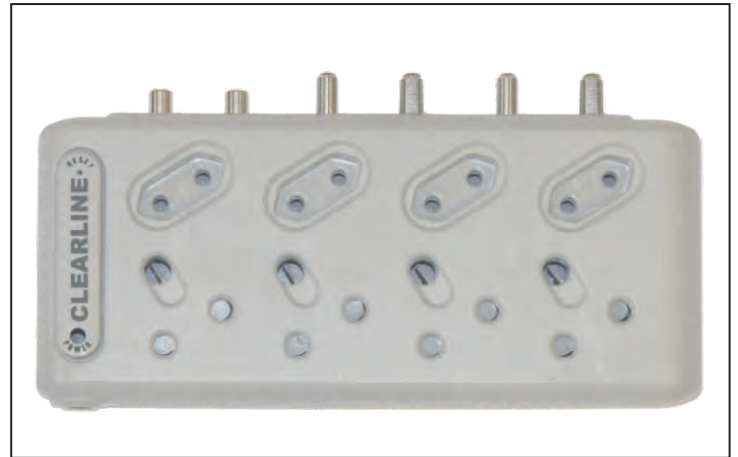

*Subject to change without prior notice due to continuous improvements

| Specifications | |
|-------------------------|------------------------------|
| Power Surge Protection | |
| Nom. Input Voltage | 230VAC 50Hz |
| Max. Continuous Current | 16A |
| Max. Discharge Current | 4.5kA L-N, L-E, N-E (8/20us) |
| Residual Voltage | <900V |
| Response Time | <25ns |
| Input Connectors | 16A 3Pin Plug |
| Output Conenctors | 4x 3Pin + 4x 2Pin Sockets |

| TV/Satellite Surge Protection | TV | Satellite |
|-------------------------------|---------------|---------------|
| Max. Discharge Current | 10kA (8/20us) | 10kA (8/20us) |
| Residual Voltage | <100V | <100V |
| Response Time | <100ns | <100ns |
| Frequency Response | 800MHz | 3GHz |
| Connectors | PAL | F-Type |

| Other | |
|---------------------|--------------|
| Indication | Neon Lamp |
| Temperature Range | 0C to +40C |
| Standard Compliance | IEC 61643-1 |
| Lead Length | 285mm |
| Dimensions | 254x112x34mm |
| Weight | 0.64kg |

Dimensions

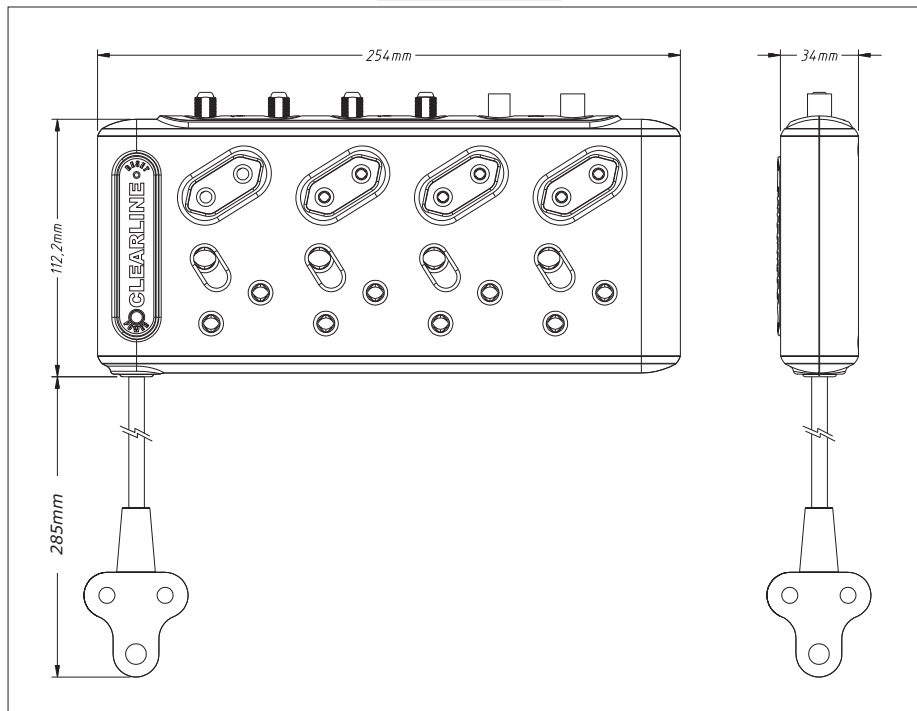

Designed and Manufactured by:

Clearline Protection Systems (Pty) Ltd

385 Roan Crescent Corporate Park North, Old Pta Road,

Midrand, South Africa

P.O. Box 5985, Halfway House, 1685

Tel: +27 (0) 11 848-1100

Fax: +27 (0) 11 314-3880

E-mail: info@clearline.co.za

www.clearline.co.za



